

Notes:

- All nail fixings pre-drilled minimum 1mm diameter smaller than nail gauge
- All products to be pre-coated & cut edges to be sealed as per Branz Bulletin 411
- All materials and fixtures are to comply with E2/AS1 clause 2.2
- Provide PVC tape bond break between H3.2 battens and any flashing
- Rigid & Flexible underlay as per table 23 and clauses 9.1.5 to 9.1.7
- Timber to NZBC B2 durability b2.3.1 (b), Western Red Cedar, Larch

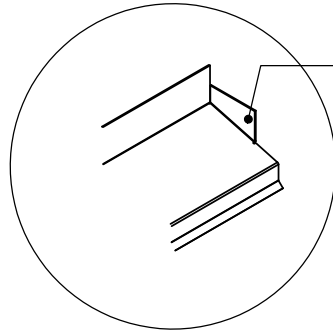

Head flashing turned up to form stop end. 50mm long  
Ensure stop ends to be installed in accordance with NZBC E2/AS1 9.1.10.4.d)

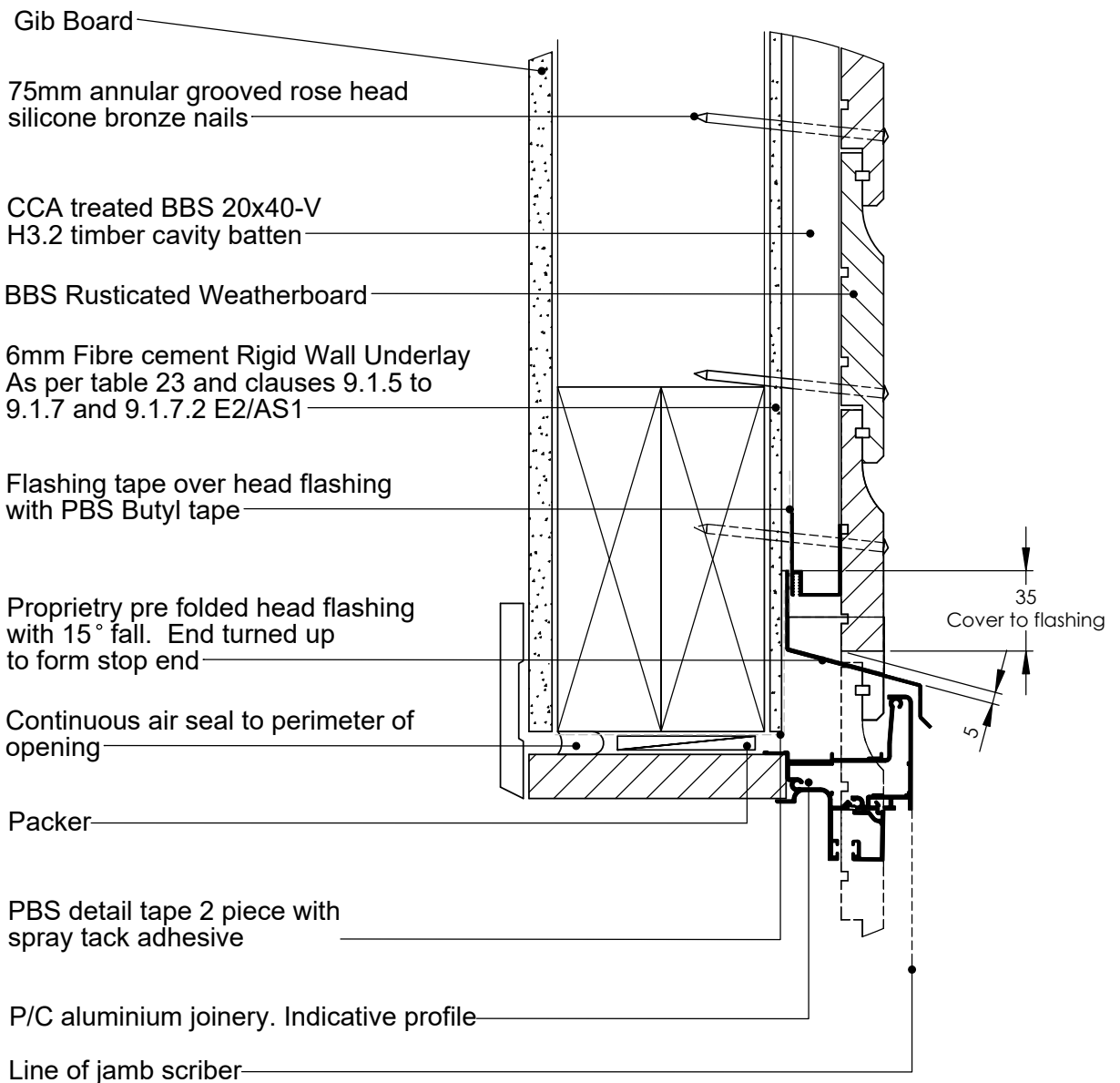

TITLE:					copyright BBS Timbers LTD ©		Aluminium Head Detail	
	NAME	SIGNATURE	DATE	Rev		27 Kioreroa road PO Box 1407 Whangarei 09 438 9358	DWG NO.	A4
DRAWN							R-RB-20	
CHK'D								
APPV'D							SCALE:1:10 DNS	SHEET 1 OF 1