

**Notes:**

- All nail fixings pre-drilled minimum 1mm diameter smaller than nail gauge
- All products to be pre-coated & cut edges to be sealed as per Branz Bulletin 411
- All materials and fixtures are to comply with E2/AS1 clause 2.2
- Provide PVC tape bond break between H3.2 battens and any flashing
- Rigid & Flexible underlay as per table 23 and clauses 9.1.5 to 9.1.7
- Timber to NZBC B2 durability b2.3.1 (b), Western Red Cedar, Larch

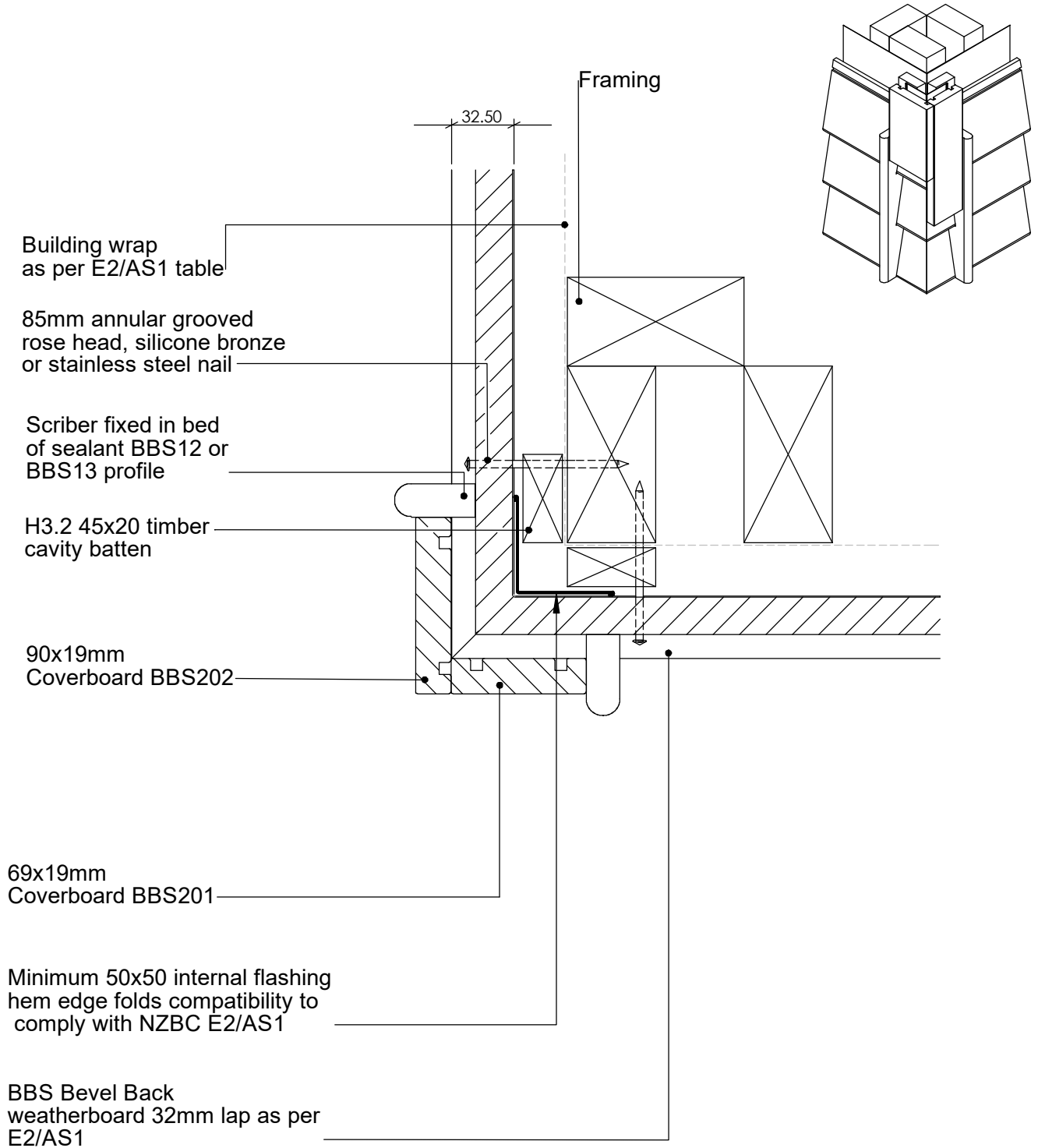

TITLE:					copyright BBS Timbers LTD ©		External corner detail	
	NAME	SIGNATURE	DATE	Rev	 27 Kioreroa road PO Box 1407 Whangarei 09 438 9358	DWG NO.	B-CW-05	A4
DRAWN								
CHK'D								
APPV'D								
						SCALE:1:5	DNS	SHEET 1 OF 1