

Notes:

- All nail fixings pre-drilled minimum 1mm diameter smaller than nail gauge
- All products to be pre-coated & cut edges to be sealed as per Branz Bulletin 411
- All materials and fixtures are to comply with E2/AS1 clause 2.2
- Provide PVC tape bond break between H3.2 battens and any flashing
- Vertical Shiplap profiles to be fixed with a minimum 2mm gap at the overlap between boards
- Rigid & Flexible underlay as per table 23 and clauses 9.1.5 to 9.1.7
- Timber to NZBC B2 durability B2.3.1 (b), Western Red Cedar, Larch

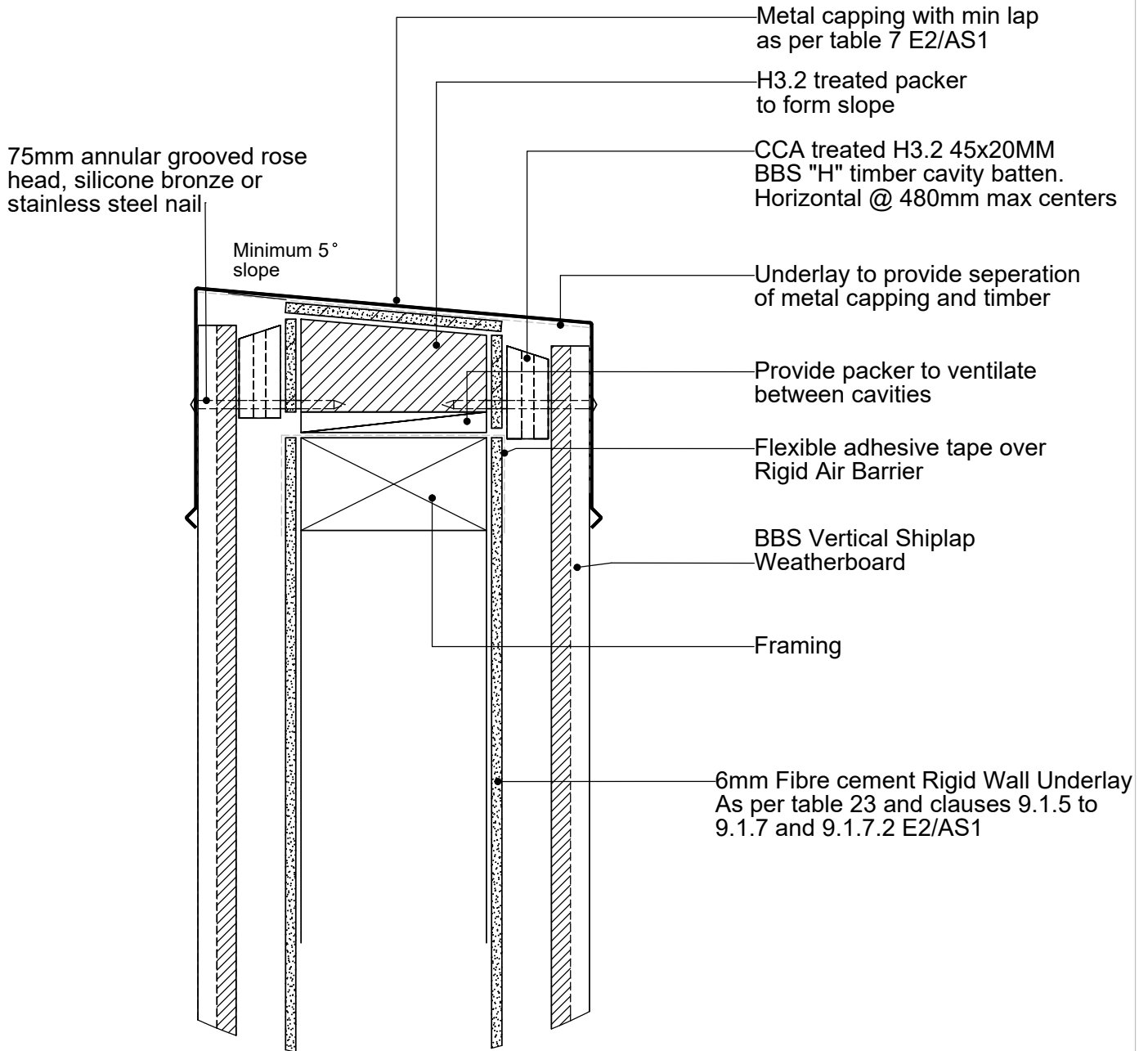

TITLE:					copyright BBS Timbers LTD ©		Parapet Detail	
	NAME	SIGNATURE	DATE	Rev		27 Kioreroa road PO Box 1407 Whangarei 09 438 9358	DWG NO.	A4
DRAWN							VC-RB-09	
CHK'D								
APP'VD								
						SCALE:1:10 DNS		SHEET 1 OF 1